

# Topcoat developments — improving functionality to suit changing challenges in labelling

Avery Dennison  
Labels and Packaging Materials

September 2019



Topcoat developments — improving functionality

## Presenters



**Ronen Scheflan**

Sales Director

[Ronen.scheflan@averydennison.com](mailto:Ronen.scheflan@averydennison.com)



**Rina Lupu Matas**

R+D Project Manager

[Rina.lupu.matas@eu.averydennison.com](mailto:Rina.lupu.matas@eu.averydennison.com)

Topcoat developments — improving functionality

## Overview



**Materials**

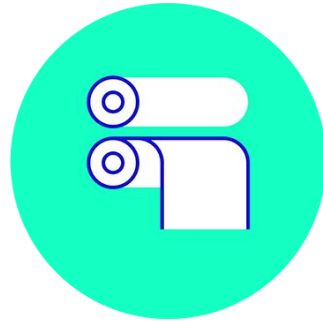

**Printability**

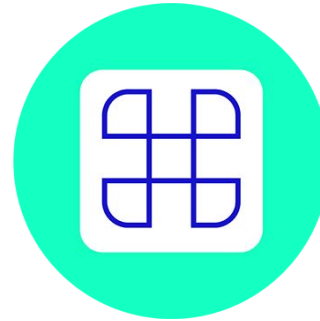

**Functionality**

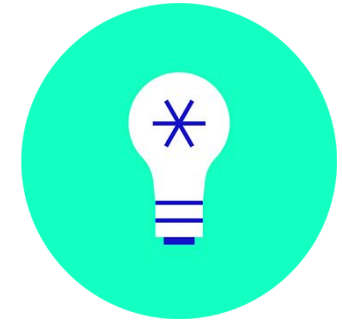



**Coating  
Developments**

Topcoat developments — improving functionality

# Agenda

Key:

Commercial   
Not yet commercial   
Under development 

## Overview of label face films — adaptations to today's needs:

### Pharma



- Luminescence 

### Security



- Watermark 
- Tamper evidence 

### Medical devices

### Industrial and durable labelling

- Flame retardant 
- Vulcanization resistance 
- On-line laser etching 

### New capabilities

- Barrier coatings 
- Indicative coatings 
- Transferable coatings 

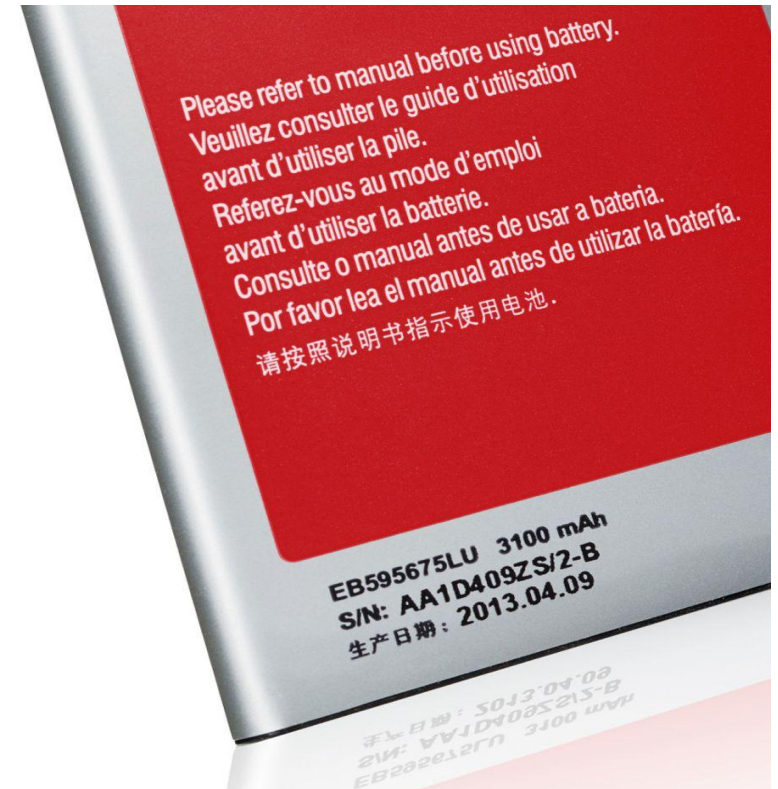

Topcoat developments — improving functionality

## Overview of label face films — adaptations to today's needs

The topcoat is applied to the face film by atmospheric coating, and upgrades the printability and/or performance of the label.

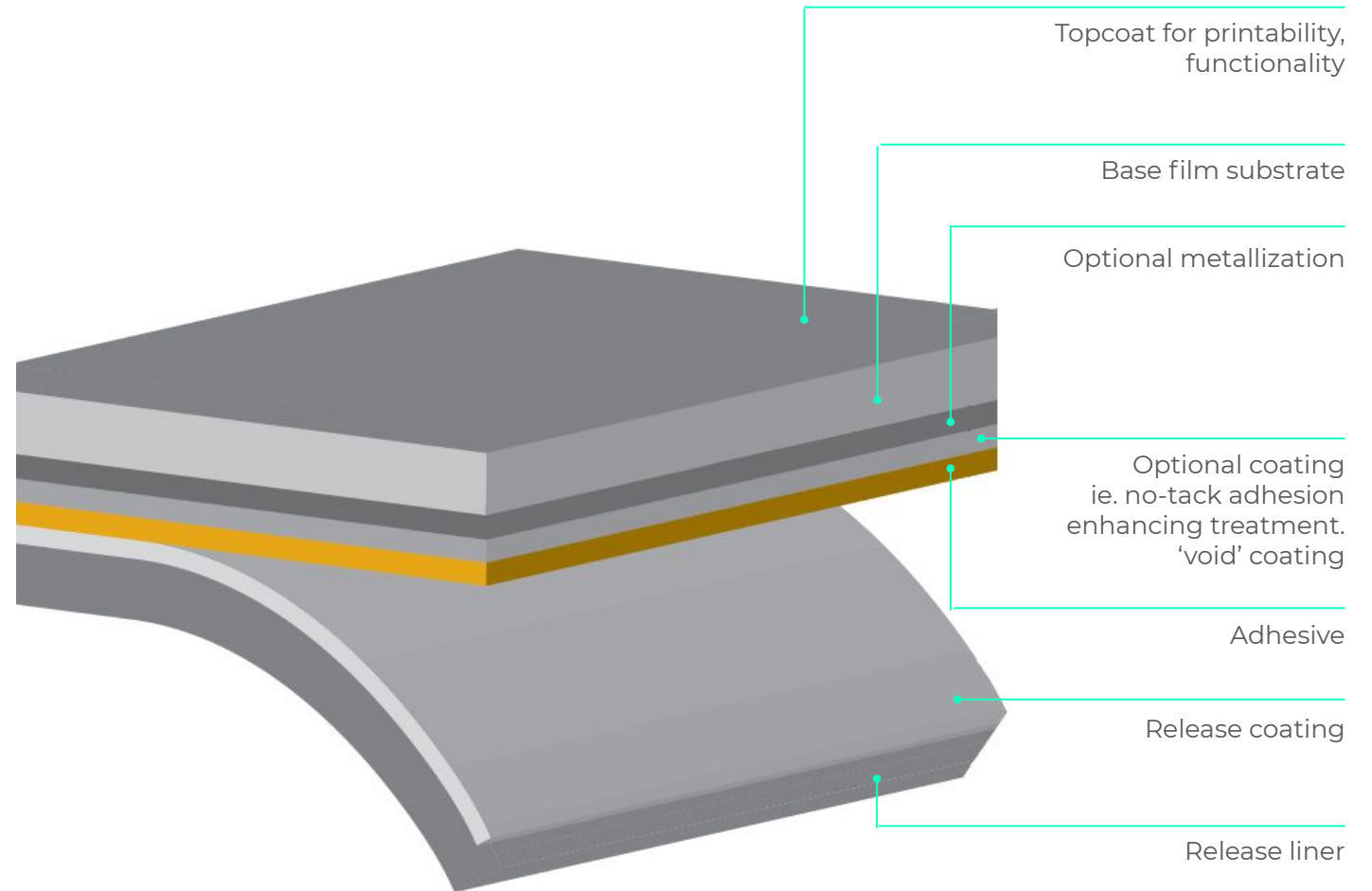

Topcoat developments — improving functionality

# Simplifying pharma compliance with luminescent topcoat

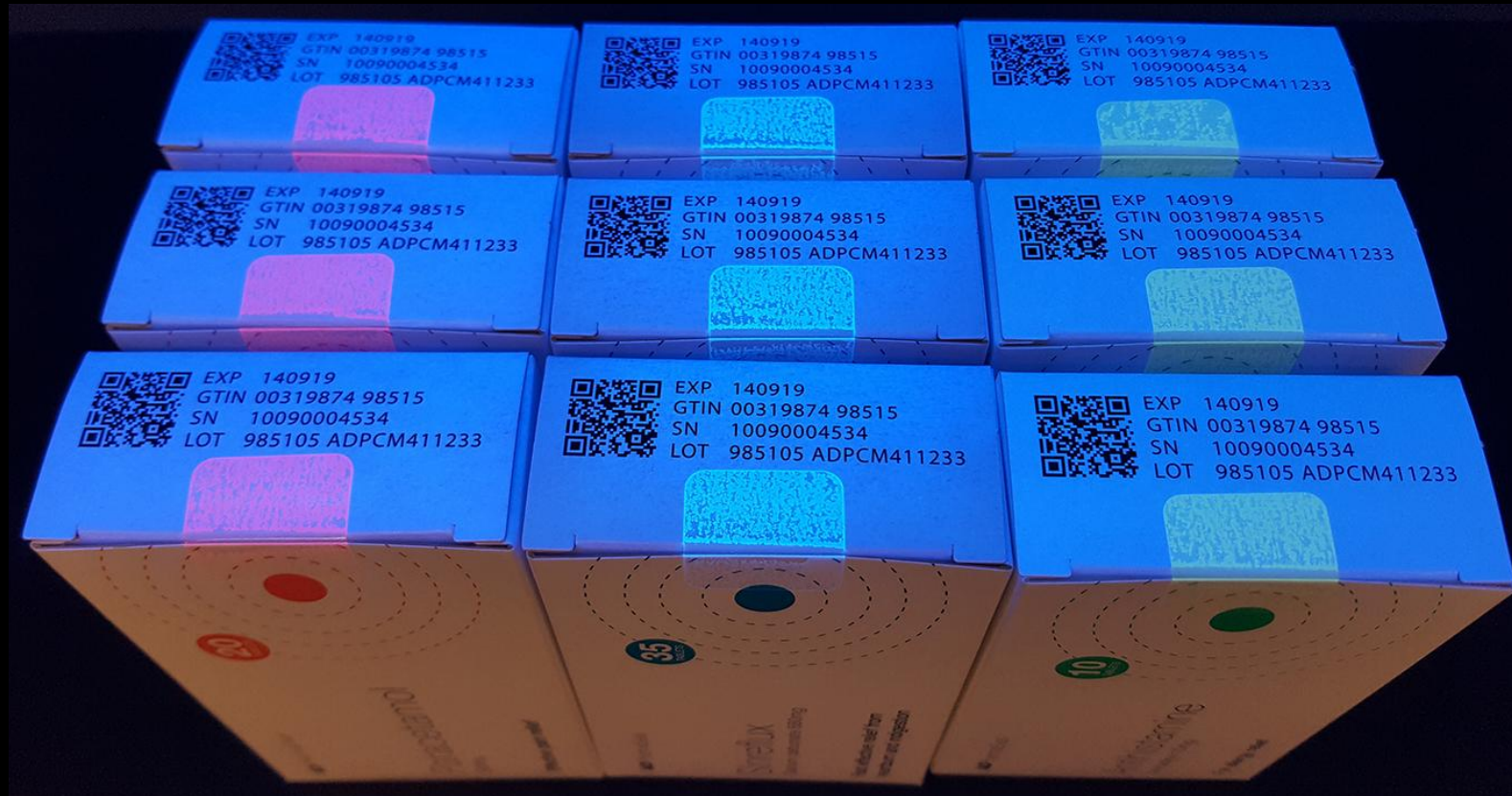

## Pharma — fulfilling sealing indication requirements



- 01.** Pharma manufacturers need to identify the presence of clear primary packaging seals and labels on dispensing lines.

This is most easily done by luminescent reaction to UV light.



- 02.** Until now, converters either add a UV varnish (tricky additional step) or use adhesive with luminescent additives, which limits the range of adhesive choices and functionality.

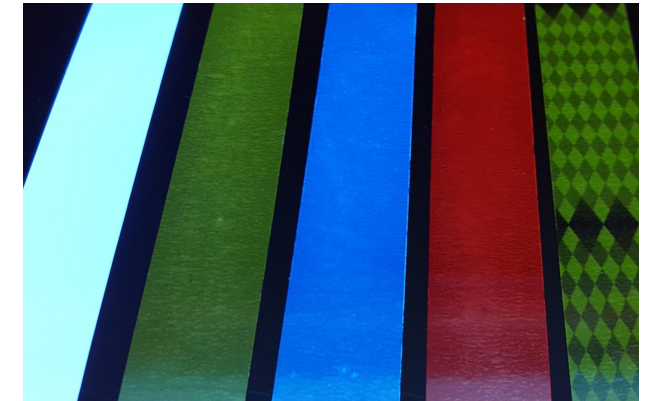

- 03.** The Luminescent range has a printable topcoat already impregnated with UV-reactive luminescent additives.

This simplifies the converting process and enables a wider adhesive portfolio.

Topcoat developments — improving functionality

## Tamper evident — variables

Vast standard portfolio, but welcome custom development integrating the range of variables.

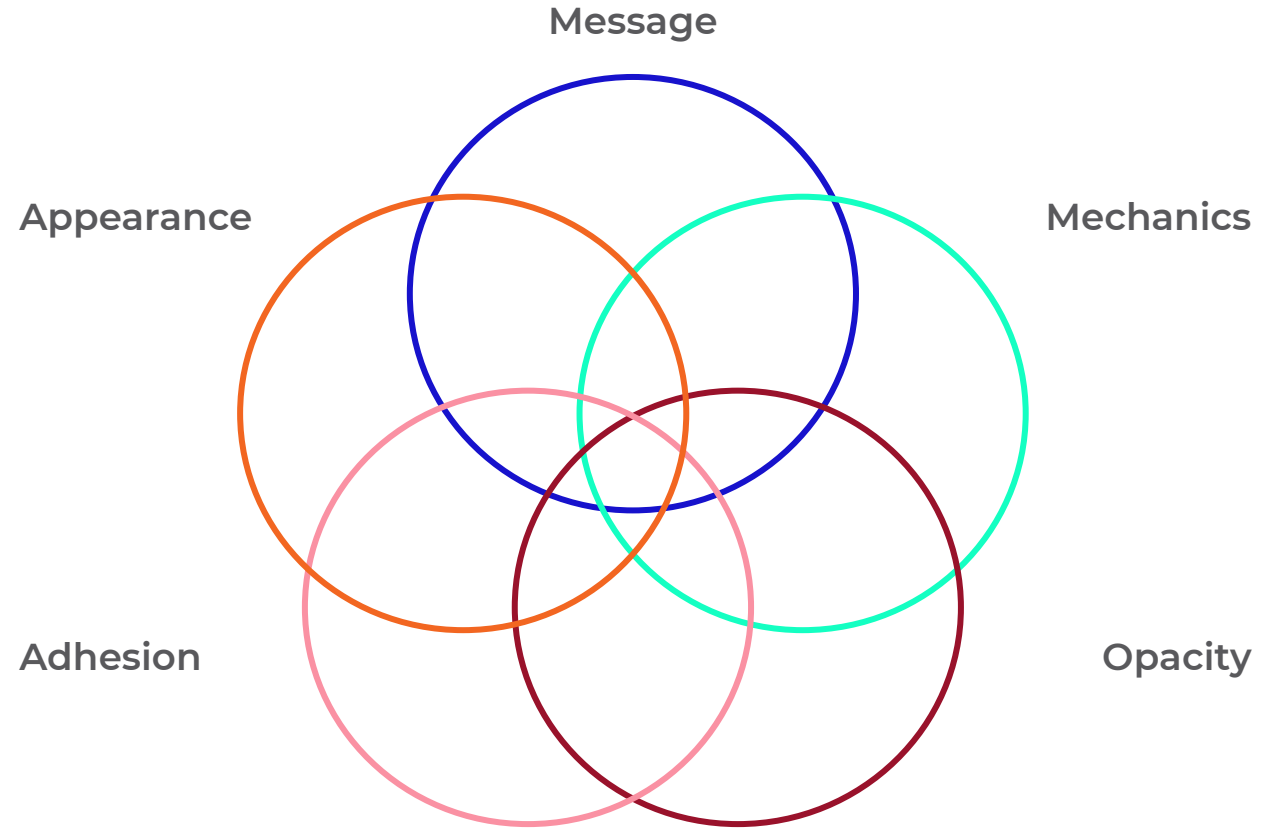



Topcoat developments — improving functionality

## Tamper evident messages can also incorporate luminescence

The UV reactive message gives a further level of identification to the label.

Topcoat developments — improving functionality

## Security — ‘Watermark’

Upgrade the security of Lumi with a ‘watermark’ imprint of logo or message for brand identification.

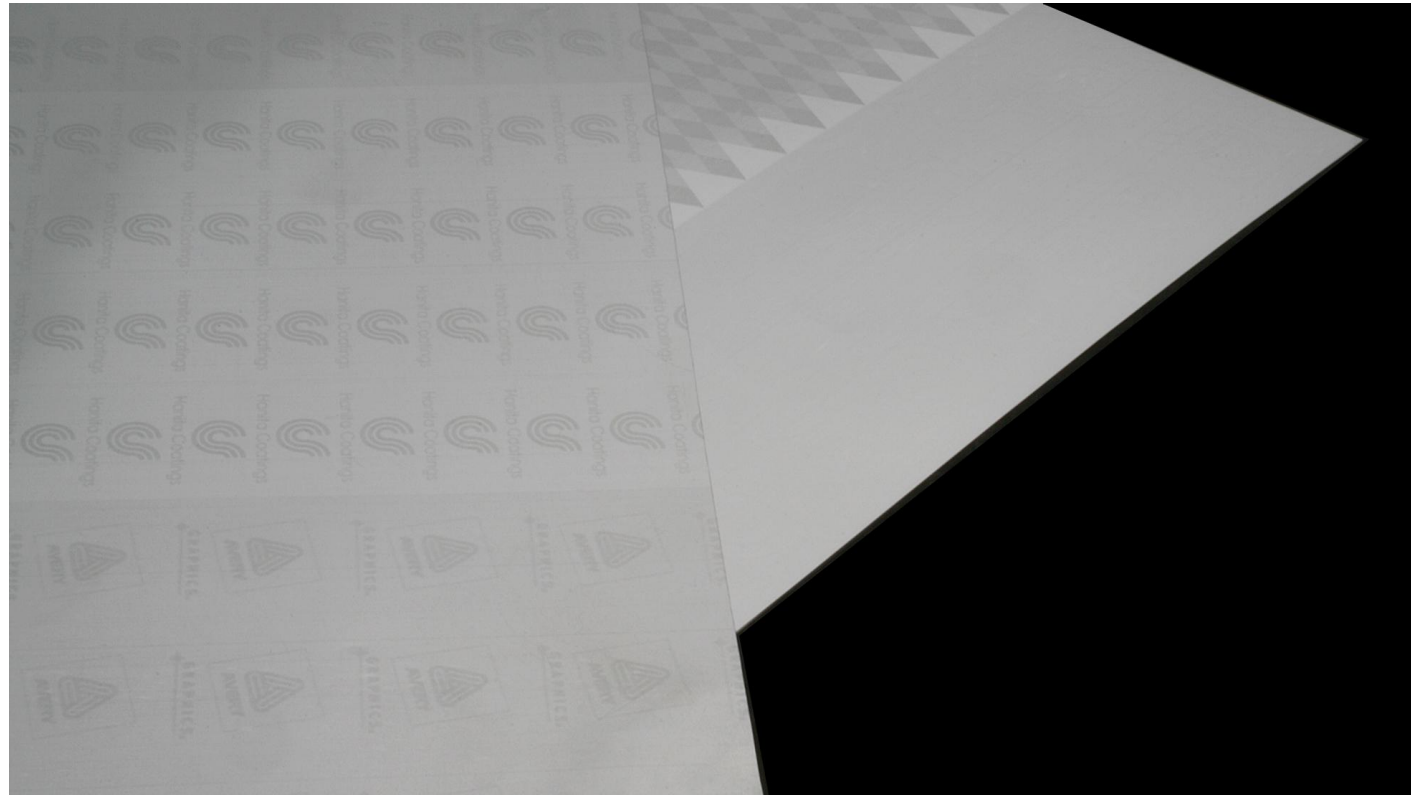

Topcoat developments — improving functionality

## Medical devices

- Antibacterial topcoat
- Chemical resistance



Topcoat developments — improving functionality

# Industrial, automotive and durable labeling

**Topcoat functionality is critical for challenging applications.**

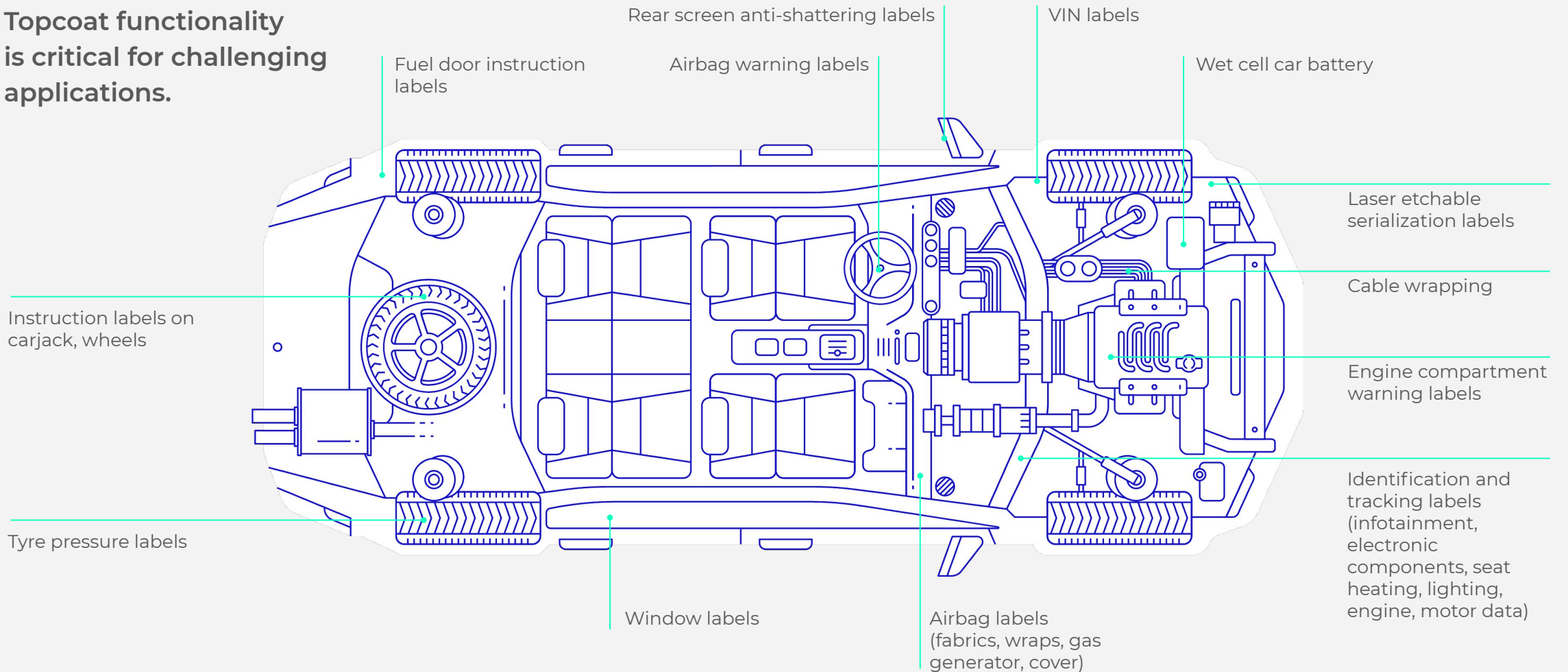

Topcoat developments — improving functionality

## New topcoat capabilities — bright ideas for the future

The latest topcoat developments deliver economic solutions.

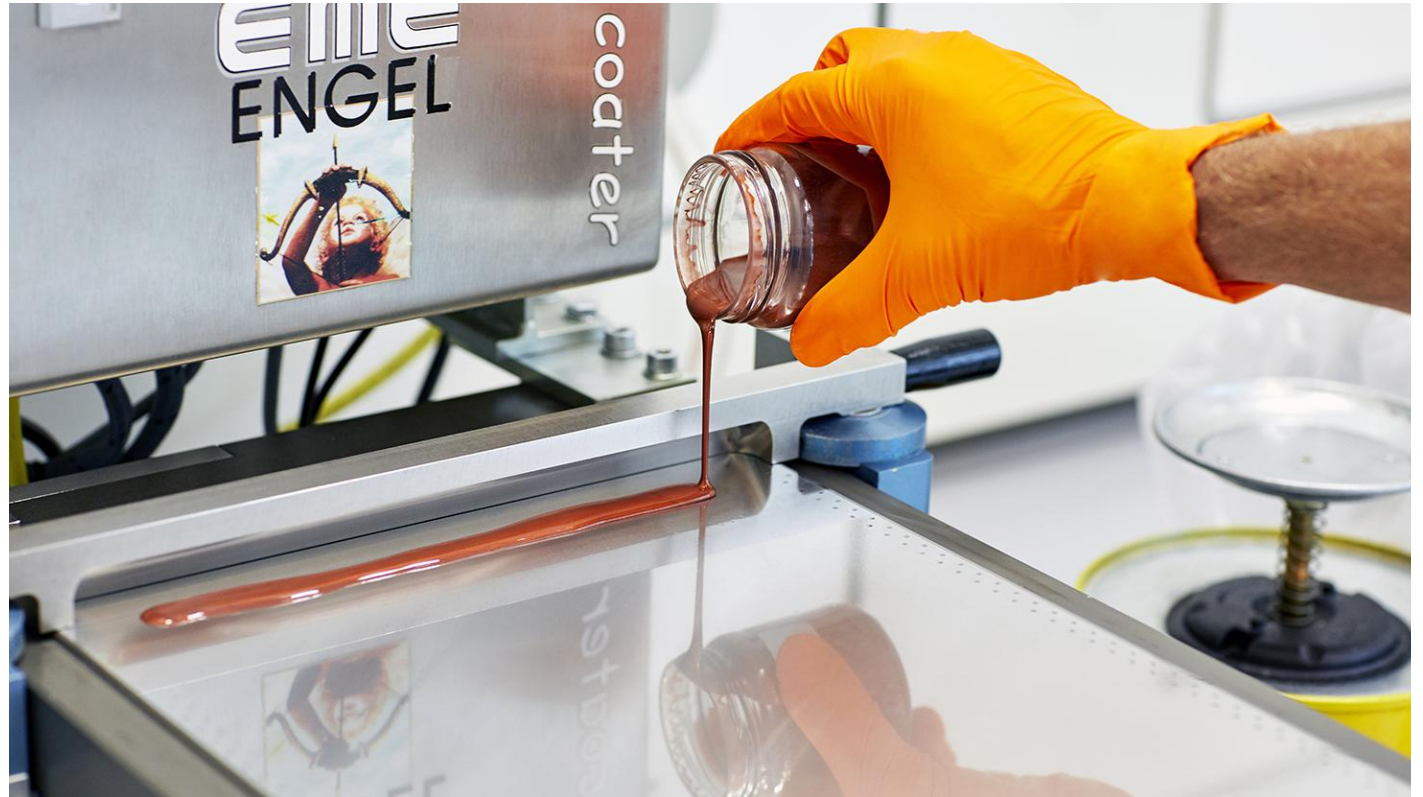

Topcoat developments — improving functionality

## Barrier coatings

Proprietary clear (or metallized) laminates that provide transparent barrier to oxygen and moisture. Ideal for packaging for perishables, pharma, medical and industrial applications.



Topcoat developments — improving functionality

## Indicative coatings

### Example:

Water-ingress labels for consumer electronics, showing distinct and irrevocable color change on direct contact with liquid.

Other developments:

- Chemicals
- Gas
- Heat.



Topcoat developments — improving functionality

## Transfer coatings

- Heat transfer labels for no-tag printed clothing, or automotive fabric labeling
- Transfer of metallization for IR heat reflection, or appearance.





## Transfer coatings

- Heat transfer labels for no-tag printed clothing, or Automotive fabric labeling
- Transfer of metallization for IR heat reflection, or appearance.

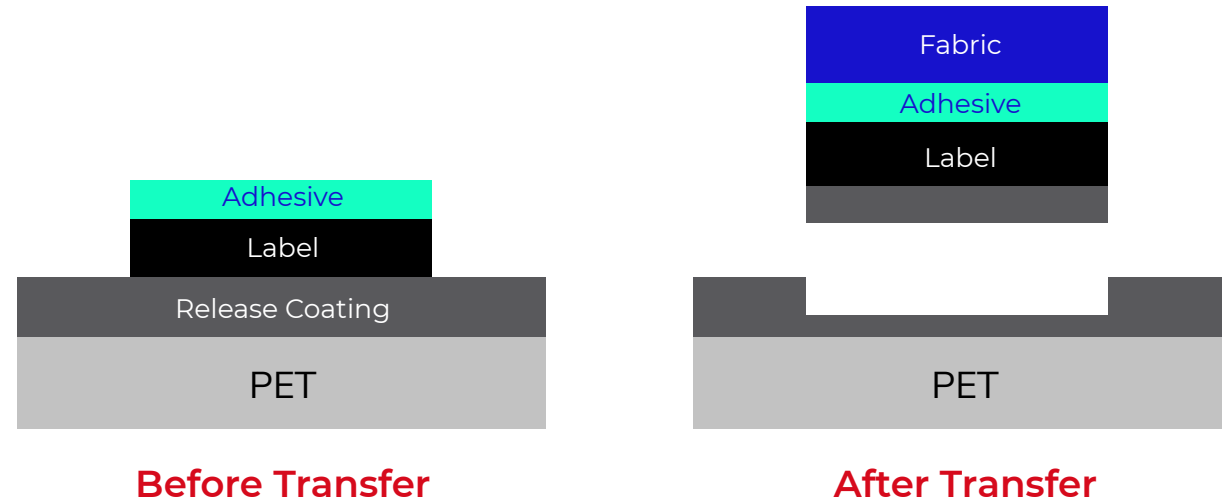

Topcoat developments — improving functionality

## Copper metallization

Enhances:

- Electrical conductivity
- Heat dissipation.

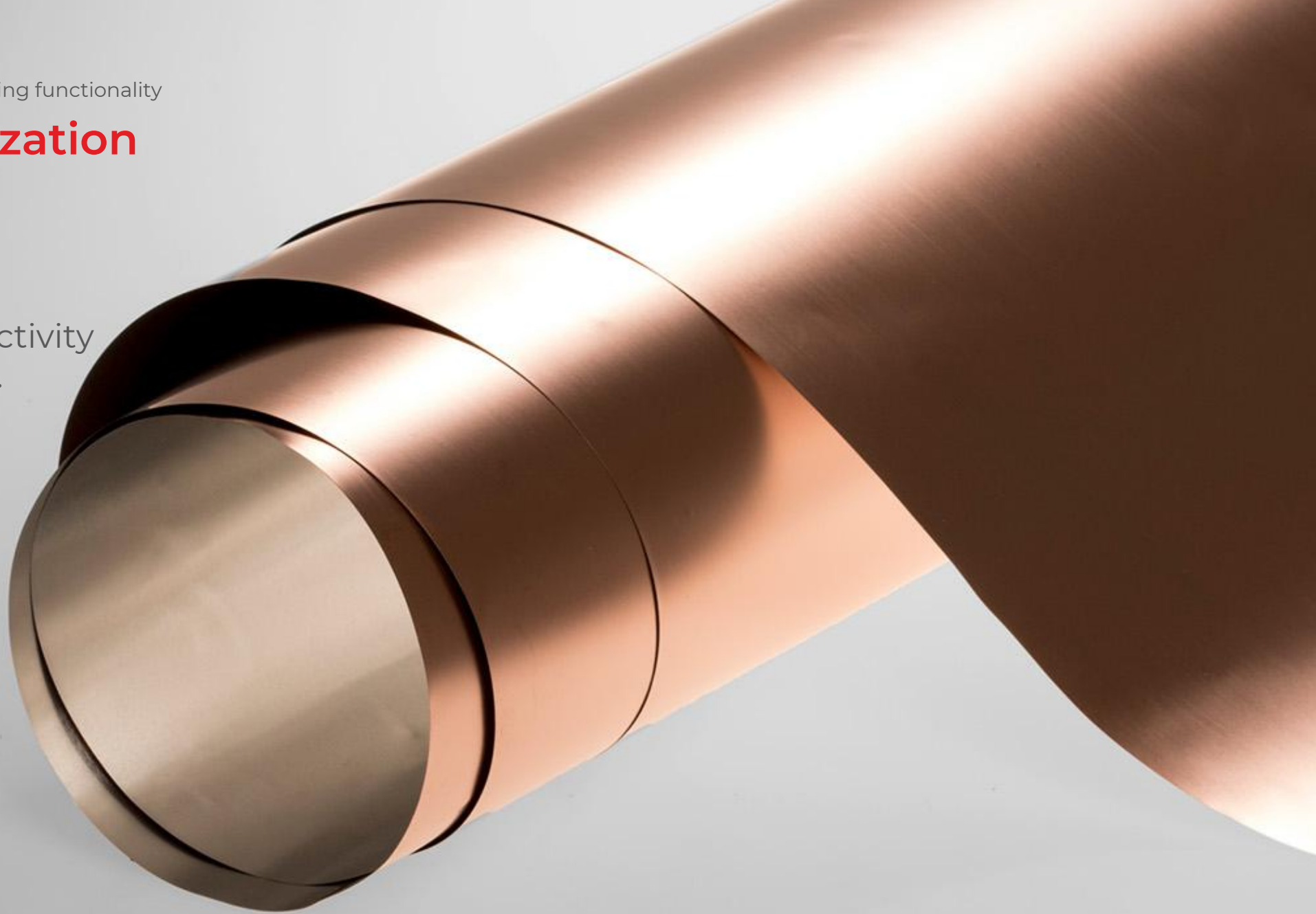

# Summary

Key:  
Not yet commercial \*  
Under development 

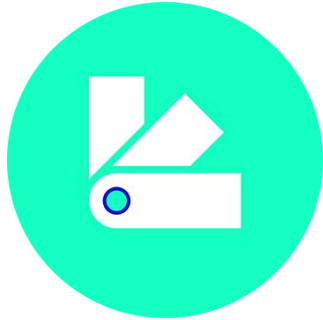

## Materials

- PET, BOPP, PE, PU, Synthetic paper
- 10-175μ
- clear, white, matte, gloss, metallized

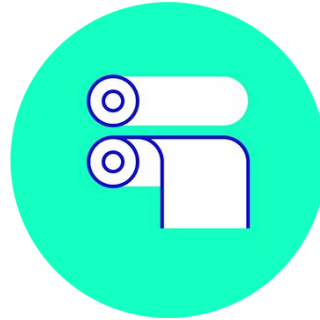

## Printability

- Digital
- Conventional
- Laser Etch \*

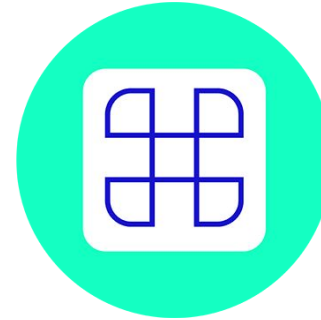

## Functionality

- Flame retardant
- Chemical and heat resistant
- Antibacterial 
- Security
- Identification
- Outdoor
- Scratch resistant

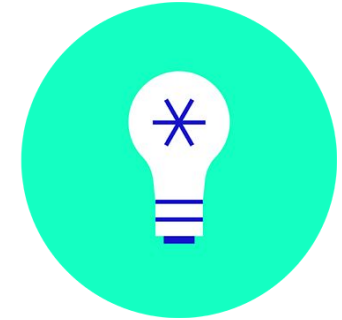

## Coating Developments

- Barrier
- Indicative 
- Transfer
- Copper 

# Thank You

[label.averydennison.com/labelexpo](http://label.averydennison.com/labelexpo)



© 2019 Avery Dennison Corporation. All rights reserved. Avery Dennison and all other Avery Dennison brands, product names and codes are trademarks of Avery Dennison Corporation. All other brands or product names are trademarks of their respective owners. Fortune 500® is a trademark of Time, Inc. Branding and other information on any samples depicted is fictitious. Any resemblance to actual names is purely coincidental.