

1 PRESSURE-SENSITIVE LABEL SUPPLIER

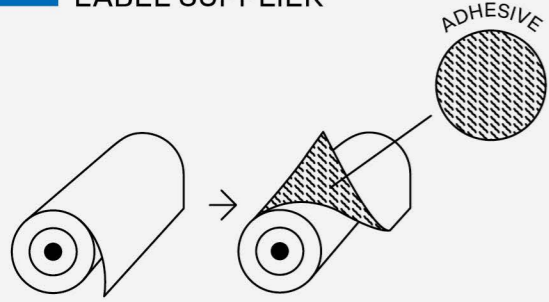

Pressure-sensitive material is created
Adhesive is laminated onto film to create pressure-sensitive construction in roll form.

2 LABEL CONVERTER PRINTER AND DIECUTTER

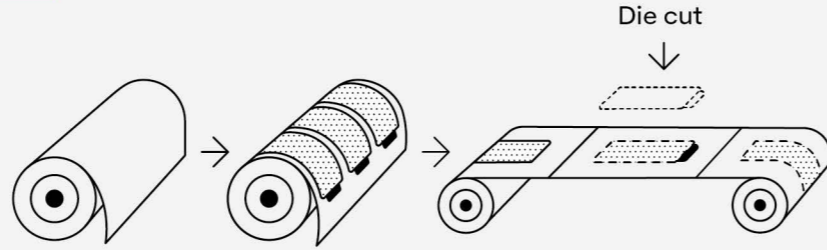

Label is printed and die cut, still on a roll with liner
Pressure-sensitive material is printed and die cut to create labels that will later be integrated with flexible packaging. Matrix is stripped.

3 WIDE WEB INTEGRATOR

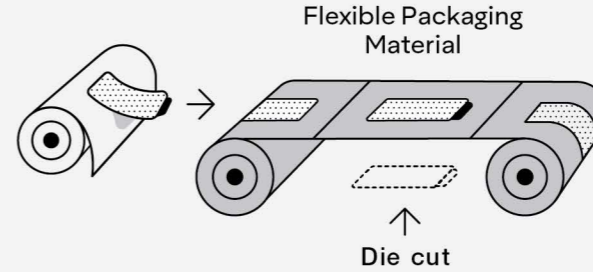

Label is applied to flexible packaging material
Labels are taken off the liner roll and placed on top of pre-printed flexible packaging material in a roll-to-roll format.

Value chain players can have capabilities in one or multiple steps in this value chain—some have invested to vertically integrate and increase the value they can add to the end product.

4 PACKAGERS

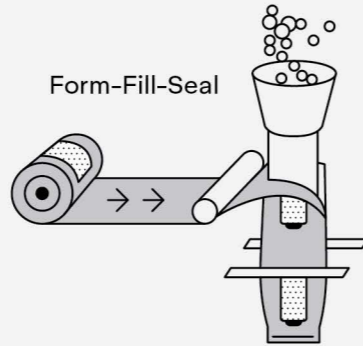
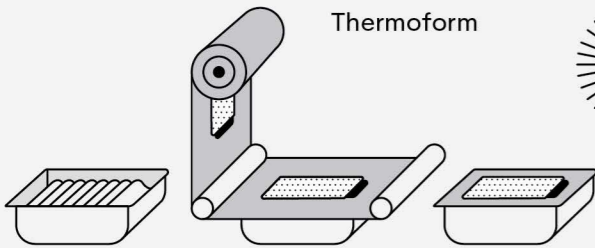

Flexible packaging material is unwound and formed into final package format
Packages are formed on heat sealing or form-fill-seal equipment.

Easy application of reclosure label to existing packaging materials, designs and formats

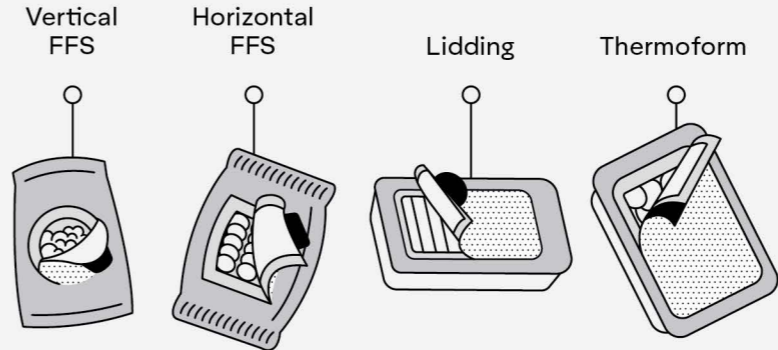

Various label sizes possible for a wide range of reclosure applications

